

Sunray™ VL Arrow Board - Hydraulic

Arrow Board Series



(Hydraulic lift version shown)

ABOUT OUR ARROW BOARD

Our Sunray™ VL Arrow Board represents the latest technical advances in vertical lift hydraulic arrow boards.

Features

- ✓ Environmentally friendly sealed battery prevents spills and leaks
- ✓ Control with touch sensitive keys and LED display uses 50% less energy which means longer run times
- ✓ Replaceable fenders means less repair time
- ✓ Curb side battery box means greater safety for the user
- ✓ Available in 36" x 72" for tight spaces like bridges
- ✓ Hydraulic lift with optional winch lift

Options

- Combo hitch 2" ball & 3" pintle ring, 8" & 18" adj.
- Battery controller
- Battery charger, 15A or 30A fanned cooled
- Wheel locks
- 14" wheels
- Cone rack
- Hidden Shackle Locks

Applications



TRAFFIC

Can be easily maneuvered, set up and controlled to work effectively in most traffic settings



CONSTRUCTION

A fitting option for construction conditions where reliable messaging is needed



MINING

Works well, both in function and sustainability, in many mining scenarios



UTILITIES

Multipurpose use for utility organizations that rely on functional, sturdy equipment



SECURITY

Ideal for temporary locations



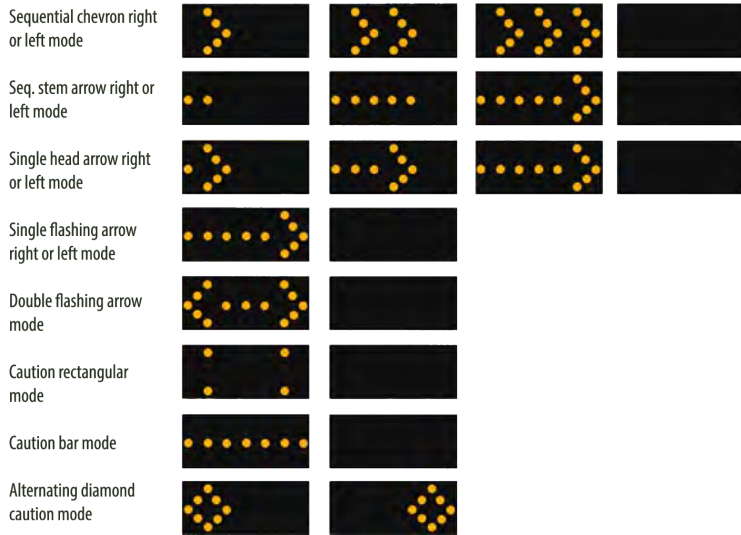

Directional Display™

Size	48" x 96" optional 36" x 72"
Front lamps	15 or 25 PAR 46 LED, 590nm
Lamp covers	Molded ABS 360°
Construction	Aluminum with internal
Rear lamps	3 PAR 35 LED
Photo sensor	Shielded from extraneous light
Rotation	360°
Brace	Multi-plate friction type, locks in any position

Control

Circuit Protection	Automotive style blade fuses
Dimming	Manual or automatic
Display	LED, shows operating mode
Meters	Voltage built-in with voltage warning and shut-down
Functions 15 lamp	7
Functions 25 lamp	12

Batteries and Solar Collectors

Batteries	(1) 12v sealed AGM, for other options: Call factory
Battery enclosure	Lockable, ventilated, acid resistant
Solar collector	Single, crystalline silicon
Solar collector frame	Formed steel, powder coated black self erecting

Trailer Construction

Deck area	43" deep x 50" wide
Drawbar	3" x 3" x 3/8" wall steel tube, removable
Fenders	formed steel bolt-on
Chassis	2" x 3" x 1/8" steel tubing, MIG welded with cross members for added strength
Mast	4" square post with locking pull latch
Length w/ drawbar	117"
Height sign up	139"
Height sign down	99"
Hitch	2" ball class II 3500 lb capacity, removable
Jacks	(4) slide type plated, (1) swing type
Tire size	ST205/75-D15 load C
Weight	1200 lbs
Winch	1000 lb. with double disc brake system, 1/4" diameter galvanized steel cable mounted on draw bar (optional electro-hydraulic lift)

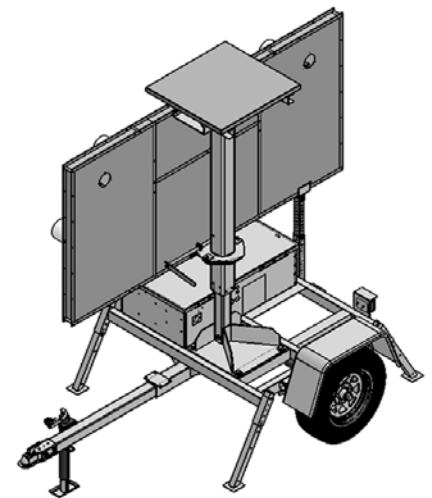
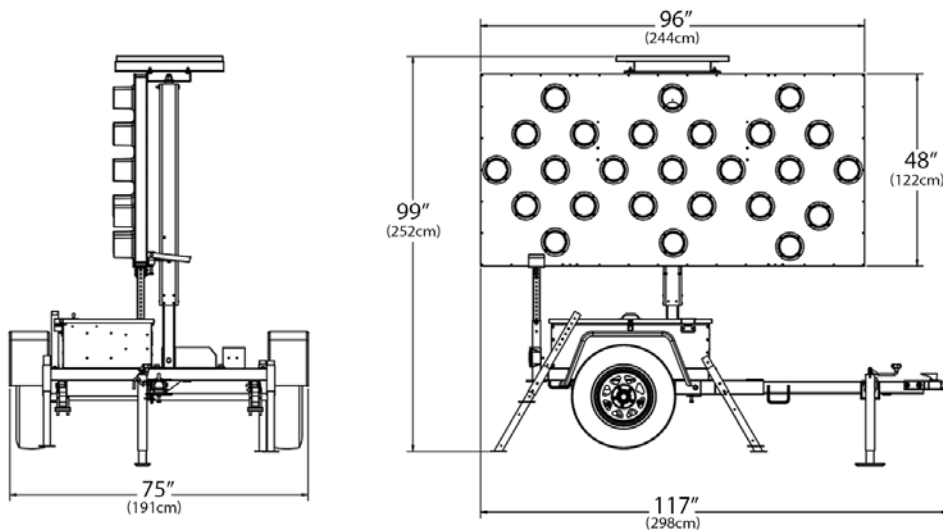

Specifications subject to change any time without notice. Copyright 2023 National Signal, Inc. All rights reserved. Printed in the United States.

