

Sunray 90

Portable Message Sign Series



ABOUT OUR MESSAGE SIGN

The Sunray 90 is a compact full matrix manual lift sign capable of displaying graphic symbols and multiple font sizes through the color touch screen. Dynamic sizing automatically fits your message as you type and message scheduling allows you to select the day, week and time that chosen messages should display.







The compact design makes it easy to maneuver and locate in tight or crowded areas. It's also ideal for situations including urban areas and special events.

Add FleetFinder and you can visually locate your fleet of signs and change messages from almost anywhere.

Features

- ✓ AllnGaP LED technology
- ✓ Numerous pre-programmed messages, MUTCD messages, and operator-created messages
- ✓ Environmentally friendly
- ✓ Cost effective
- ✓ Reliable and easy to operate
- ✓ Optional hydraulic lift and remote programming
- ✓ Replace characters without the need of tools
- ✓ 3 or 4 LED's per pixel

Options

-  **REMOTE OPERATION**
Standard cellular modem or FleetFinder™
-  **SPEED DETECTION**
-  **COMBO HITCH**
With 8" to 18" adjustment
-  **HIDDEN SHACKLE LOCKS**
For securing batteries
-  **WHEEL LOCKS**
-  **ELECTRO HYDRAULIC LIFT**
-  **GPS MODULE**



Trailer Construction

Width across fenders	75"
Drawbar	3" x 3" x .375" wall steel tube / removable
Fenders	formed steel replaceable
Frame	2" x 3" x 1/8" wall tubing
Length w/ drawbar	106" (42" x 75"), 113" (50" x 88")
Length w/o drawbar	83" (42" x 75"), 90" (50" x 88")
Height sign up	137"
Height sign down	99"
Hitch	2" ball class II 3500 lb capacity
Jacks	(4) slide, (1) swing type
Tire size	ST205/75-D15 load C
Weight	1250 lbs
Lift mechanism	1,000 lb with double disc brake 1/4" diameter steel rope cable rated 4,400 lb. Electro-hydraulic optional

Batteries and Solar Collectors

Batteries	12v deep cycle
Battery charger	15A fanned cooled
Battery enclosure	Lockable, ventilted, steel
Solar collector	Crystalline sollicon, 120w

Dimensions

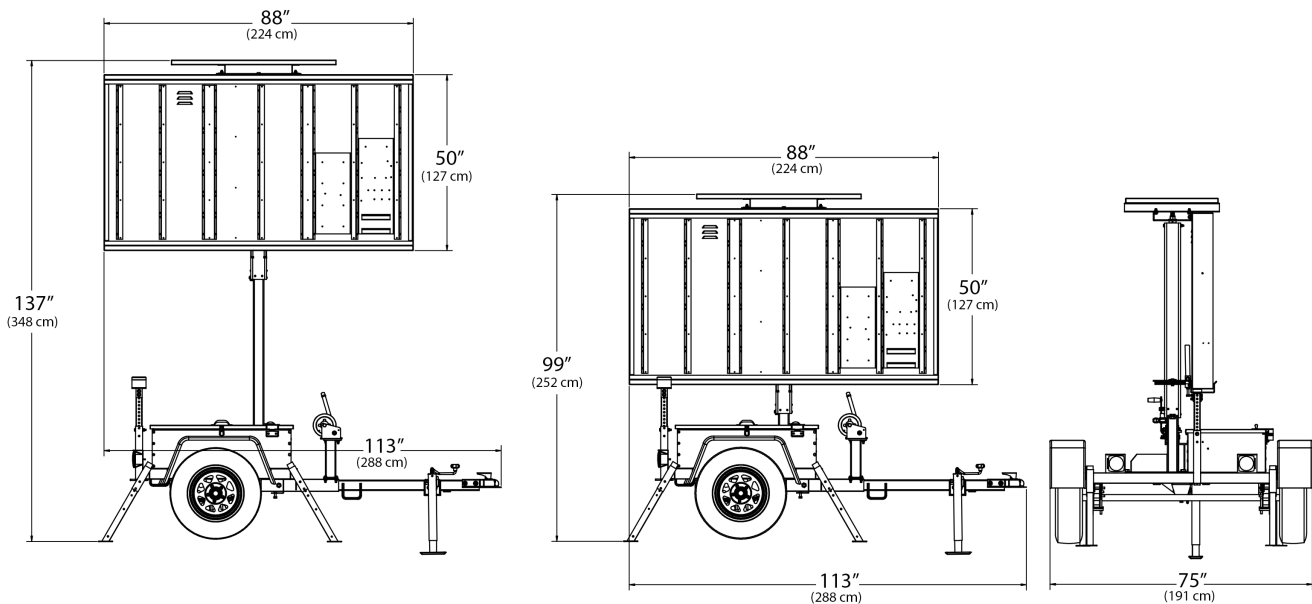

Specifications subject to change any time without notice. Copyright 2023 National Signal, Inc. All rights reserved. Printed in the United States.

Display

Sign size	42" x 75", 28 x 48 pixels 50" x 88", 28 x 48 pixels
Fonts	7" H 10/line (3) lines 10" H 9/line (3) lines 11.5" H 9/line (3) line 24" H 3/line (1) line
Window	1/8" clear polycarbonate
Sign case	One piece, aluminum, powder coat black
LED's	Amber, 590nm, 4 per pixel
Characters	Replaceable without need for tools

Control

Type	Proprietary embedded, fully NTCIP compliant
Dimming	Manual or automatic
Remote Comm	Cellular capable
Messages	50 user programmable (6 pages each), 200 pre-programmed including MUTCD symbols and arrows
Message scheduling	36 events
Interface	Color touch tablet with built-in graphic and text libraries

